



Features

- Output voltage tolerance $\leq \pm 2\%$
- 200 mA output current capability
- Low-drop voltage
- Very low standby current consumption
- Overtemperature protection
- Reverse polarity protection
- Short-circuit proof
- Adjustable reset threshold
- Watchdog
- Wide temperature range
- Suitable for use in automotive electronics
- Green Product (RoHS compliant)
- AEC Qualified

Functional Description

TLE 4263 is a 5-V low drop voltage regulator in a SMD package PG-DSO-14-30, PG-DSO-20-35, or PG-DSO-8-16. The maximum input voltage is 45 V. The maximum output current is more than 200 mA. The IC is short-circuit proof and incorporates temperature protection which turns off the IC at overtemperature.

The IC regulates an input voltage V_I in the range of $6\text{ V} < V_I < 45\text{ V}$ to $V_{Q,nom} = 5.0\text{ V}$. A reset signal is generated for an output voltage of $V_{Q,rt} < 4.5\text{ V}$. This voltage threshold can be decreased to 3.5 V by external connection of a voltage divider. The reset delay can be set externally by a capacitor. The integrated watchdog logic supervises the connected microcontroller. The IC can be switched off via the inhibit input, which causes the current consumption to drop from 900 μA to typical 0 μA .

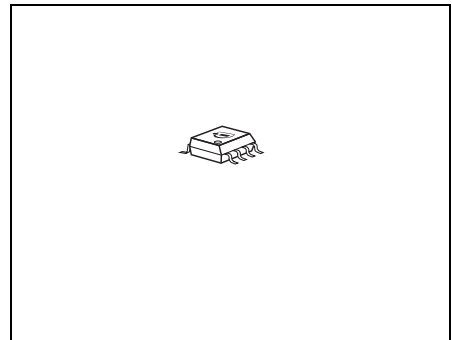
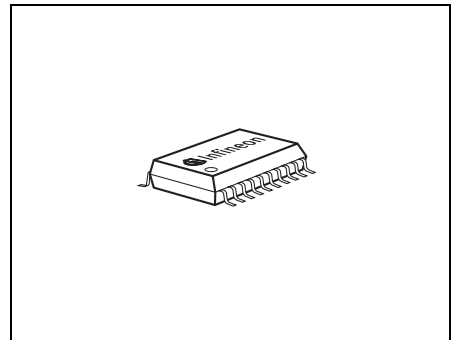
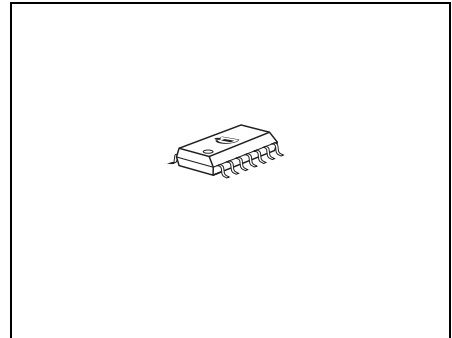

Type	Package	Type	Package
TLE 4263 GS	PG-DSO-8-16	TLE 4263 GM	PG-DSO-14-30
TLE 4263 G	PG-DSO-20-35		

Choosing External Components

The input capacitor C_I is necessary for compensation of line influences. Using a resistor of approx. $1\ \Omega$ in series with C_I , the oscillating circuit consisting of input inductivity and input capacitance can be damped. The output capacitor is necessary for the stability of the regulating circuit. Stability is guaranteed at values $\geq 22\ \mu\text{F}$ and an ESR of $\leq 3\ \Omega$ within the operating temperature range. For small tolerances of the reset delay the spread of the capacitance of the delay capacitor and its temperature coefficient should be noted.

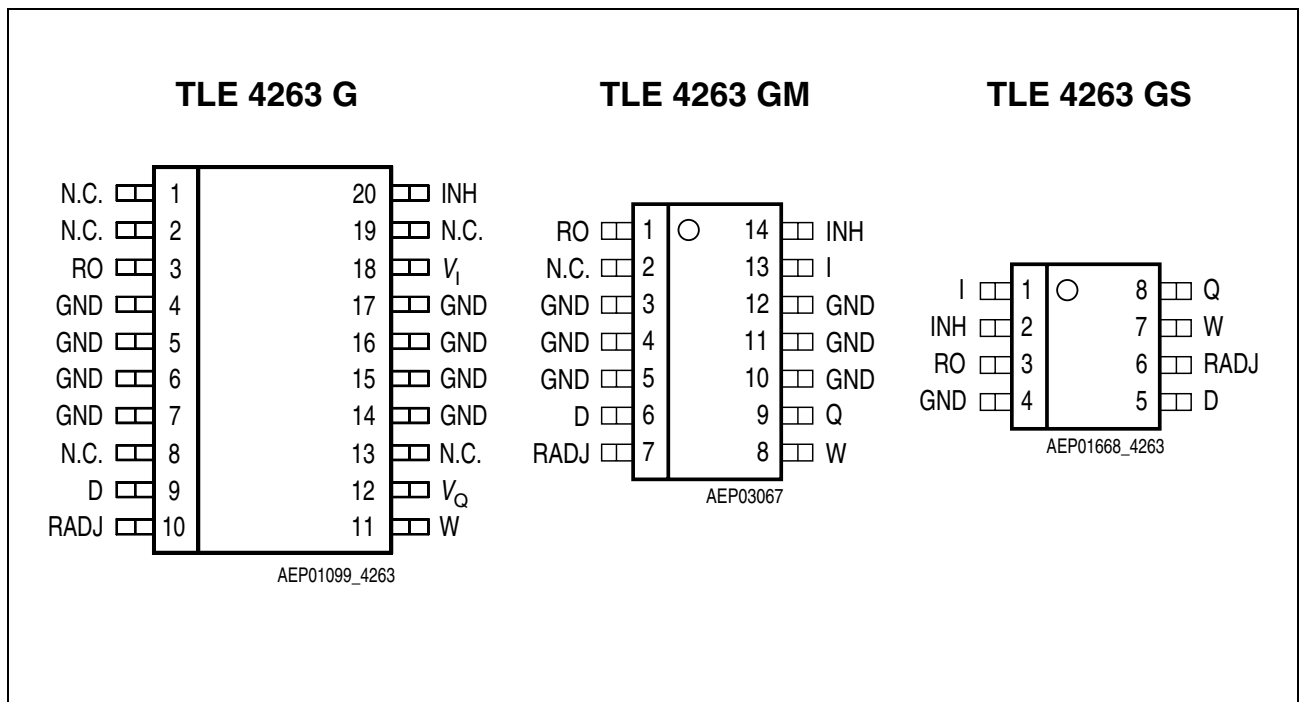

Figure 1 Pin Configuration (top view)

Table 1 Pin Definitions and Functions

Pin PG-DSO-14 -30	Pin PG-DSO-20- 35	Pin PG-DSO-8 -16	Symbol	Function
1	3	3	RO	Reset output; open-collector output connected to the output via a resistor of 30 kΩ.
2	1, 2, 19, 13	–	N.C.	Not connected
3 - 5, 10 - 12	4-7, 14-17	4	GND	Ground
6	9	5	D	Reset delay; connected to ground with a capacitor.
7	10	6	RADJ	Reset threshold; to adjust the switching threshold connect a voltage divider (output to GND) to the pin. If this input is connected to GND, reset is triggered at an output voltage of 4.5 V.
8	11	7	W	Watchdog; rising edge triggered input for monitoring a microcontroller.
9	12	8	Q	5-V output voltage; block to ground with a capacitor, $C \geq 22 \mu\text{F}$, $\text{ESR} \leq 3 \Omega$ at 10 kHz
13	18	1	I	Input voltage; block to ground directly at the IC with a ceramic capacitor.
14	20	2	INH	Inhibit; TTL-compatible, low-active input.

Circuit Description

The control amplifier compares a reference voltage, which is kept highly accurate by resistance adjustment, to a voltage that is proportional to the output voltage and drives the base of the series transistor via a buffer. Saturation control as a function of the load current prevents any over-saturation of the power element. If the externally scaled down output voltage at the reset threshold input drops below 1.35 V, the external reset delay capacitor is discharged by the reset generator. When the voltage of the capacitor reaches the lower threshold V_{DRL} , a reset signal occurs at the reset output and is held until the upper threshold V_{DU} is exceeded. If the reset threshold input is connected to GND, reset is triggered at an output voltage of typ. 4.65 V. A connected microcontroller will be monitored through the watchdog logic. In case of missing pulses at pin W, the reset output is set to low. The pulse sequence time can be set in a wide range with the reset delay capacitor. The IC can be switched at the TTL-compatible, low-active inhibit input. The IC also incorporates a number of internal circuits for protection against:

- Overload
- Overtemperature
- Reverse polarity

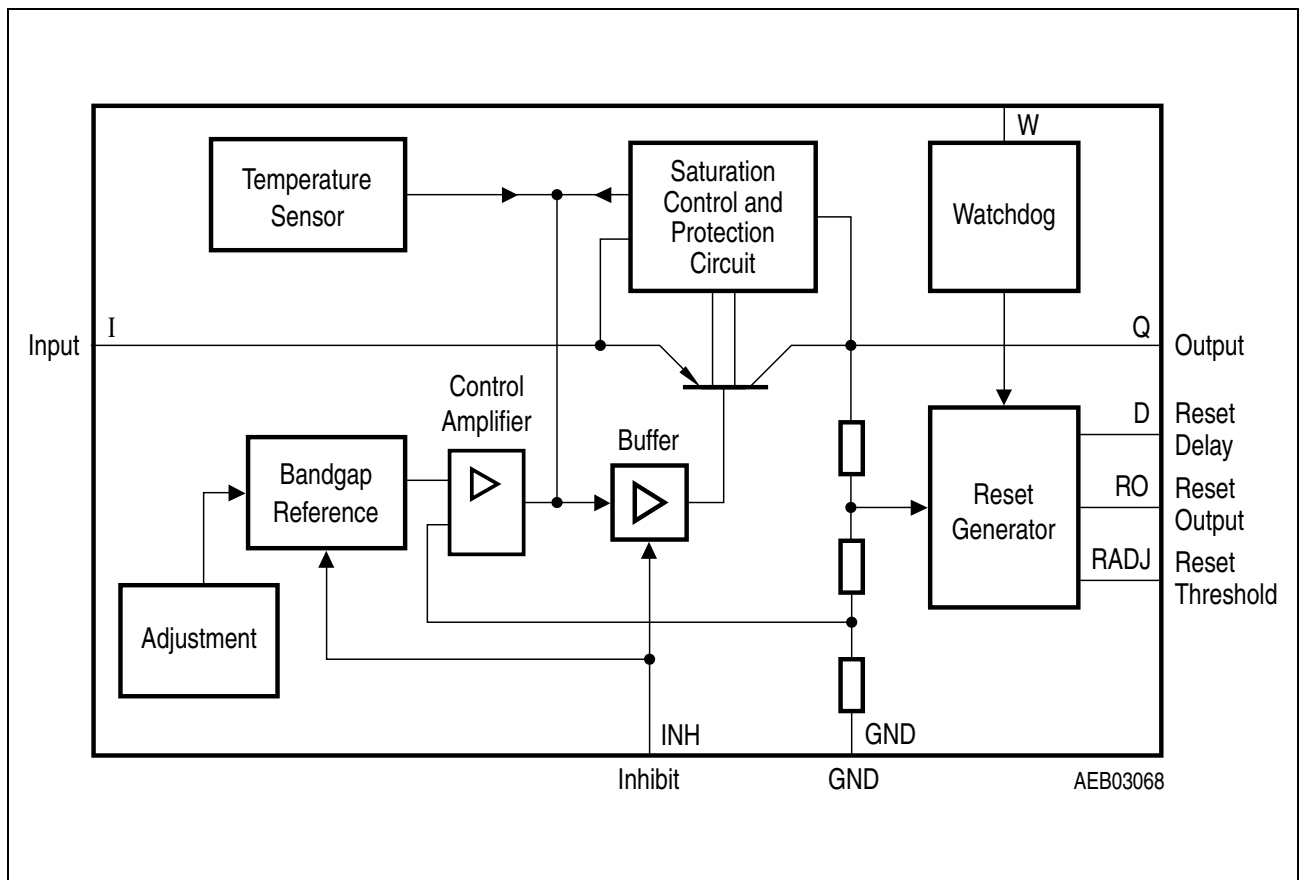

Figure 2 Block Diagram

Table 2 Absolute Maximum Ratings

Parameter	Symbol	Limit Values		Unit	Remarks
		Min.	Max.		
Input I					
Input voltage	V_I	-42	45	V	–
Input current	I_I	–	–	–	internally limited
Reset Output RO					
Voltage	V_R	-0.3	42	V	–
Current	I_R	–	–	–	internally limited
Reset Threshold RADJ					
Voltage	V_{RADJ}	-0.3	6	V	–
Reset Delay D					
Voltage	V_D	-0.3	42	V	–
Current	I_D	–	–	–	internally limited
Output Q					
Voltage	V_Q	-0.3	7	V	–
Current	I_Q	–	–	–	internally limited
Inhibit INH					
Voltage	V_{INH}	-42	45	V	–
Watchdog W					
Voltage	V_W	-0.3	6	V	–
Ground GND					
Current	I_{GND}	-0.5	–	A	–
Temperature					
Junction temperature	T_j	–	150	°C	–
Storage temperature	T_{stg}	-50	150	°C	–
Operating Range					
Input voltage	V_I	–	45	V	–
Junction temperature	T_j	-40	150	°C	–

Table 2 Absolute Maximum Ratings (cont'd)

Parameter	Symbol	Limit Values		Unit	Remarks
		Min.	Max.		
Thermal Resistance					
Junction-ambient	R_{thj-a}	–	112	K/W	PG-DSO-14-30 ¹⁾ ; Footprint only
		–	92	K/W	PG-DSO-14-30 ¹⁾ ; 300 mm ² Heat sink
		–	185	K/W	PG-DSO-8-16 ¹⁾ ; Footprint only
		–	164	K/W	PG-DSO-8-16 ¹⁾ ; 300 mm ² Heat sink
Junction-pin	R_{thj-p}	–	32	K/W	PG-DSO-14-30 ²⁾

1) Worst case; package mounted on PCB 80 × 80 × 1.5 mm³; 35μ Cu; 5μ Sn; zero airflow.

2) Measured to pin 4.

Table 3 Characteristics
 $V_I = 13.5 \text{ V}; -40 \text{ }^\circ\text{C} < T_j < 125 \text{ }^\circ\text{C}; V_{\text{INH}} > 3.5 \text{ V};$ (unless specified otherwise)

Parameter	Symbol	Limit Values			Unit	Test Condition
		Min.	Typ.	Max.		
Normal Operation						
Output voltage	V_Q	4.90	5.00	5.10	V	$5 \text{ mA} \leq I_Q \leq 150 \text{ mA};$ $6 \text{ V} \leq V_I \leq 28 \text{ V}$
Output voltage	V_Q	4.90	5.00	5.10	V	$6 \text{ V} \leq V_I \leq 32 \text{ V};$ $I_Q = 100 \text{ mA};$ $T_j = 100 \text{ }^\circ\text{C}$
Output current	I_Q	200	250	400	mA	¹⁾
Current consumption; $I_q = I_I - I_Q$	I_q	–	0	50	μA	$V_{\text{INH}} = 0$
	I_q	–	900	1300	μA	$I_Q = 0 \text{ mA}$
	I_q	–	10	18	mA	$I_Q = 150 \text{ mA}$
	I_q	–	15	23	mA	$I_Q = 150 \text{ mA}; V_I = 4.5 \text{ V}$
Drop voltage	V_{dr}	–	0.35	0.50	V	$I_Q = 150 \text{ mA}^{1)}$
Load regulation	$\Delta V_{Q,\text{lo}}$	–	–	25	mV	$I_Q = 5 \text{ mA to } 150 \text{ mA}$
Line regulation	$\Delta V_{Q,\text{li}}$	–	3	25	mV	$V_I = 6 \text{ V to } 28 \text{ V};$ $I_Q = 150 \text{ mA}$
Power Supply Ripple Rejection	$PSRR$	–	54	–	dB	$f_r = 100 \text{ Hz};$ $V_r = 0.5 \text{ Vpp}$
Reset Generator						
Switching threshold	$V_{Q,\text{rt}}$	4.5	4.65	4.8	V	$V_{\text{RADJ}} = 0 \text{ V}$
Reset adjust threshold	$V_{\text{RADJ,th}}$	1.26	1.35	1.44	V	$V_Q > 3.5 \text{ V}$
Reset low voltage	$V_{\text{RO,l}}$	–	0.10	0.40	V	$I_{\text{RO}} = 1 \text{ mA}$
Saturation voltage	$V_{\text{D,sat}}$	–	50	100	mV	$V_Q < V_{\text{R,th}}$
Upper timing threshold	V_{DU}	1.45	1.70	2.05	V	–
Lower reset timing threshold	V_{DRL}	0.20	0.35	0.55	V	–
Charge current	$I_{\text{D,ch}}$	40	60	85	μA	–
Reset delay time	t_{rd}	1.3	2.8	4.1	ms	$C_{\text{D}} = 100 \text{ nF}$
Reset reaction time	t_{rr}	0.5	1.2	4	μs	$C_{\text{D}} = 100 \text{ nF}$

Table 3 Characteristics (cont'd)
 $V_i = 13.5 \text{ V}; -40 \text{ }^\circ\text{C} < T_j < 125 \text{ }^\circ\text{C}; V_{\text{INH}} > 3.5 \text{ V};$ (unless specified otherwise)

Parameter	Symbol	Limit Values			Unit	Test Condition
		Min.	Typ.	Max.		
Watchdog						
Discharge current	$I_{\text{D,wd}}$	4.40	6.25	9.10	μA	$V_{\text{D}} = 1.0 \text{ V}$
Upper timing threshold	V_{DU}	1.45	1.70	2.05	V	–
Lower timing threshold	V_{DWL}	0.20	0.35	0.55	V	–
Watchdog trigger time	$T_{\text{WI,tr}}$	16	22.5	27	ms	$C_{\text{D}} = 100 \text{ nF}$
Inhibit						
Switching voltage	$V_{\text{INH,ON}}$	3.6	–	–	V	IC turned on
Turn-OFF voltage	$V_{\text{INH,OFF}}$	–	–	0.8	V	IC turned off
Input current	I_{INH}	5	10	25	μA	$V_{\text{INH}} = 5 \text{ V}$

1) Drop voltage = $V_i - V_{\text{Q}}$ (measured when the output voltage has dropped 100 mV from the nominal value obtained at 6 V input).

Note: The reset output is low within the range $V_{\text{Q}} = 1 \text{ V}$ to $V_{\text{Q,rt}}$.

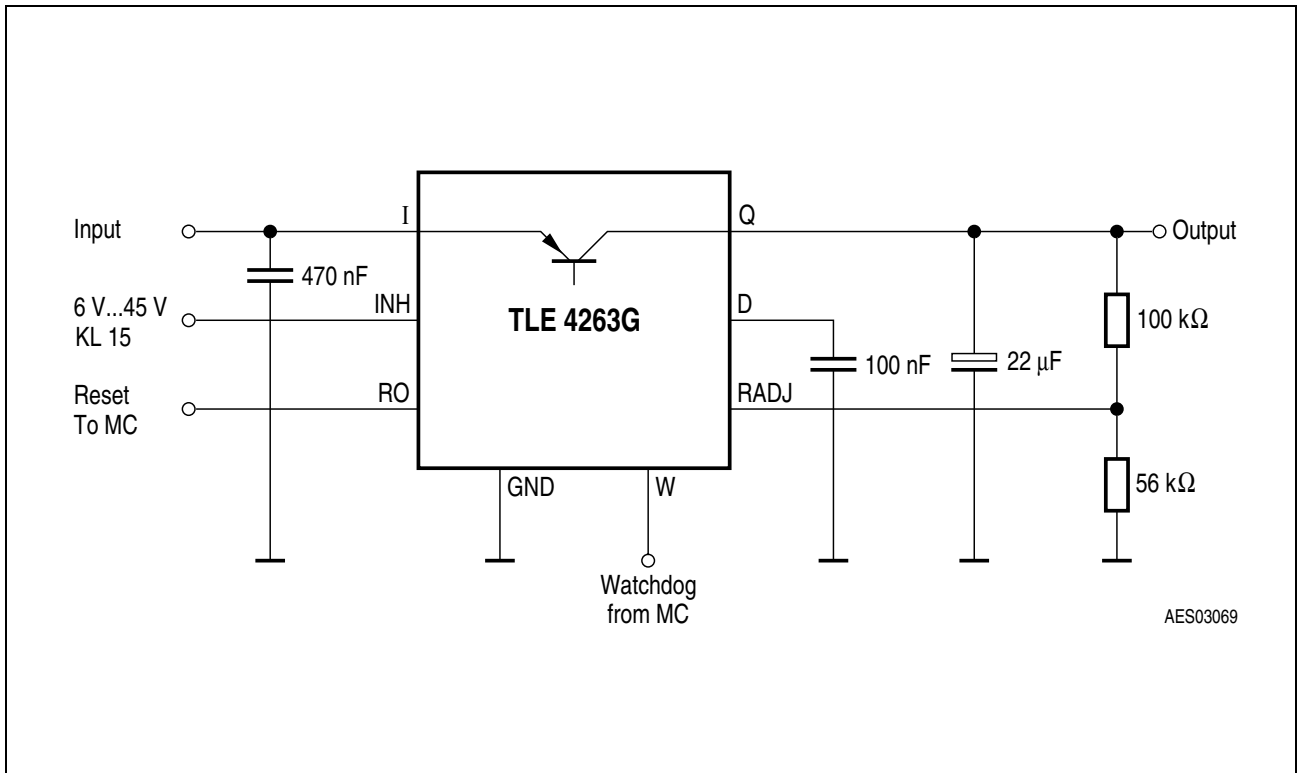

AES03069

Figure 3 Application Circuit

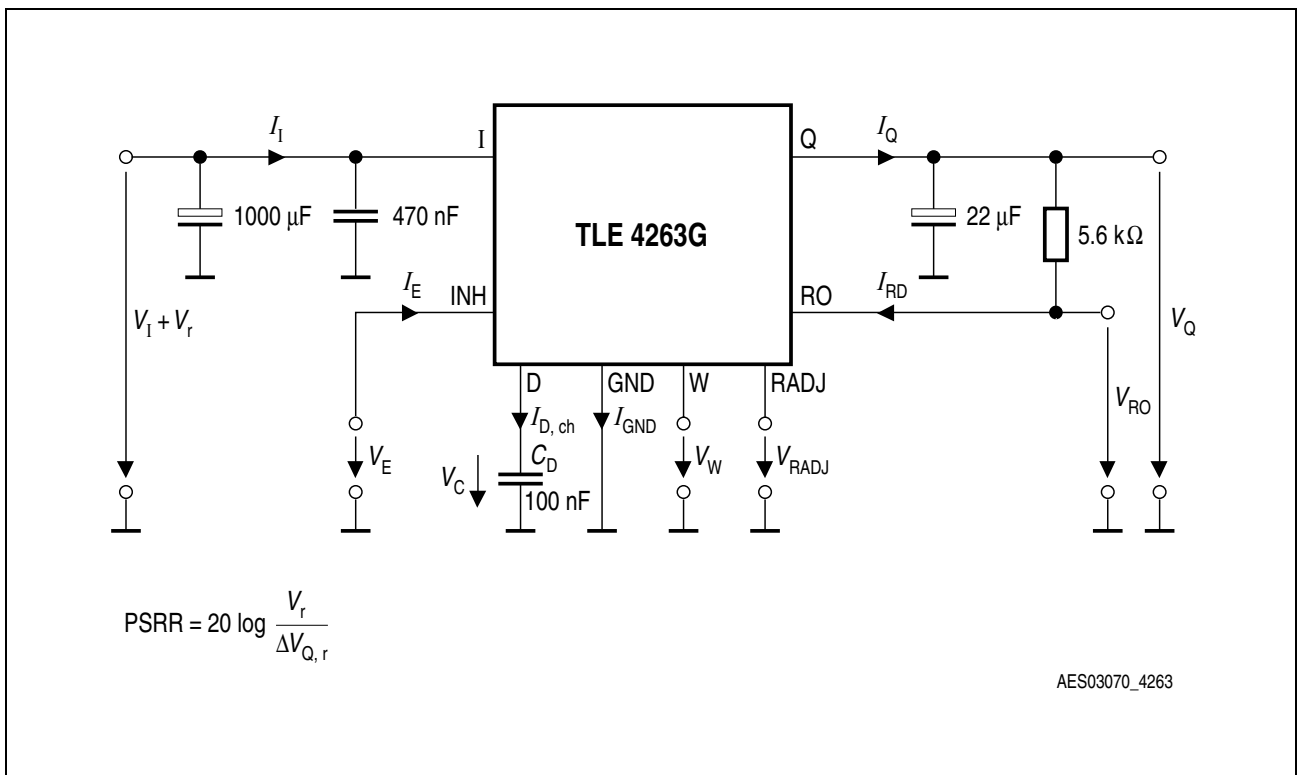

AES03070_4263

Figure 4 Test Circuit

Reset Timing

The power-on reset delay time is defined by the charging time of an external capacitor C_D which can be calculated as follows:

$$C_D = (t_{rd} \times I_{D,ch}) / \Delta V \tag{1}$$

Definitions:

- C_D = delay capacitor
- t_{rd} = reset delay time
- $I_{D,ch}$ = charge current, typical 60 μ A
- $\Delta V = V_{DU}$, typical 1.70 V
- V_{DU} = upper delay switching threshold at C_D for reset delay time

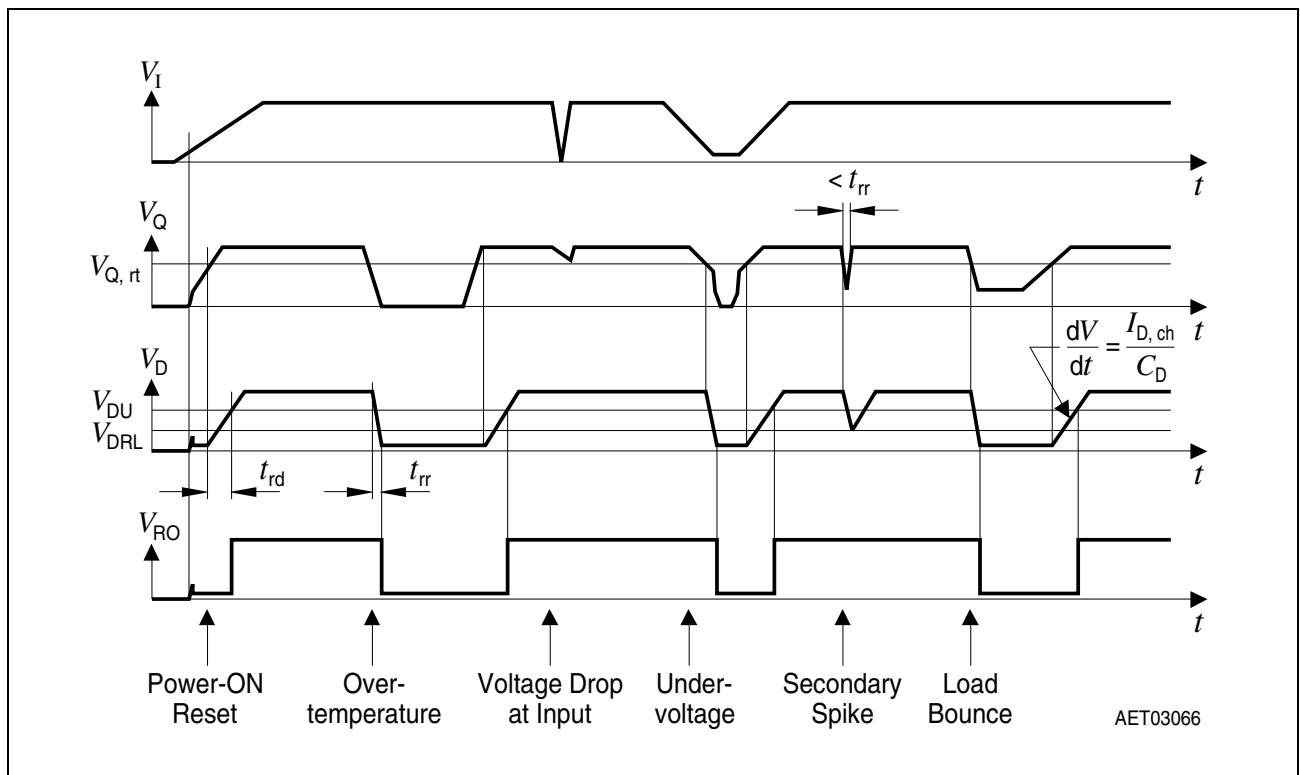

Figure 5 Time Response, Watchdog with High-Frequency Clock

Reset Switching Threshold

The present default value is typ. 4.65 V. When using the TLE 4263 the reset threshold can be set to $3.5\text{ V} < V_{Q,rt} < 4.6\text{ V}$ by connecting an external voltage divider to pin RADJ. The calculation can be easily done since the reset adjust input current can be neglected. If this feature is not needed, the pin has to be connected to GND.

$$V_{Q,rt} = (1 + R_1/R_2) \times V_{RADJ,th} \tag{2}$$

Definitions:

- $V_{Q,rt}$ = reset threshold
- $V_{RADJ,th}$ = comparator reference voltage, typical 1.35 V

Watchdog Timing

The frequency of the watchdog pulses has to be higher than the minimum pulse sequence which is set by the external reset delay capacitor C_D . Calculation can be done according to the formula given in [Figure 6](#).

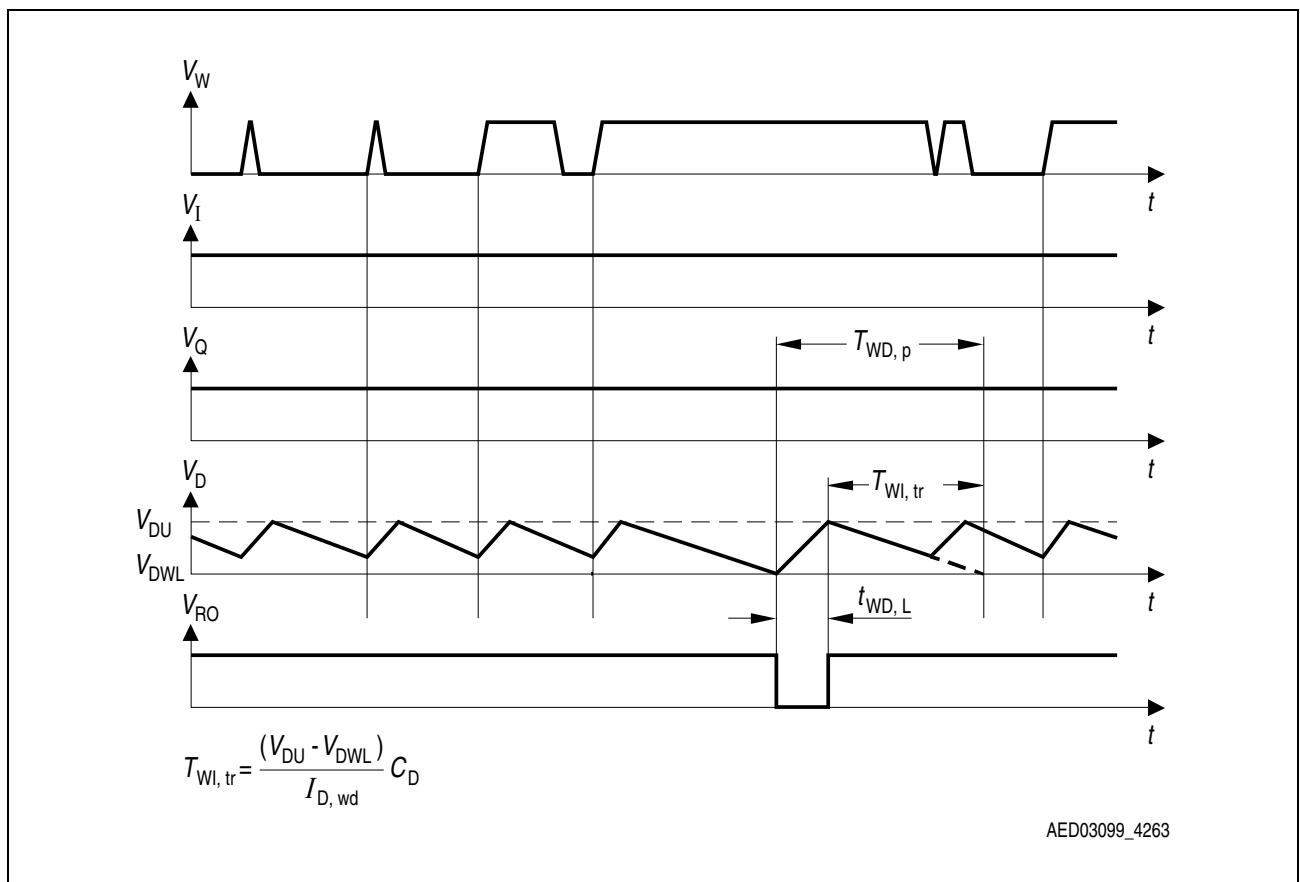
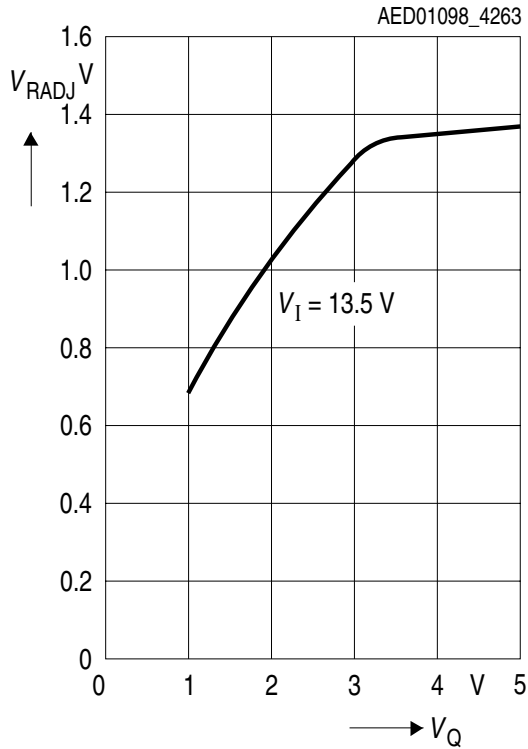
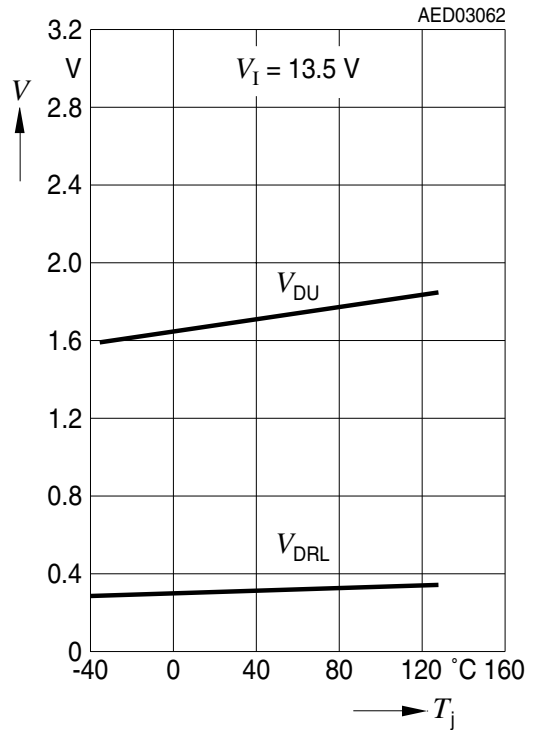

Figure 6 Timing of the Watchdog Function Reset

Reset Switching Threshold versus Output Voltage



Timing Threshold Voltage V_{DU} and V_{DRL} versus Temperature



Reset Switching Threshold versus Temperature

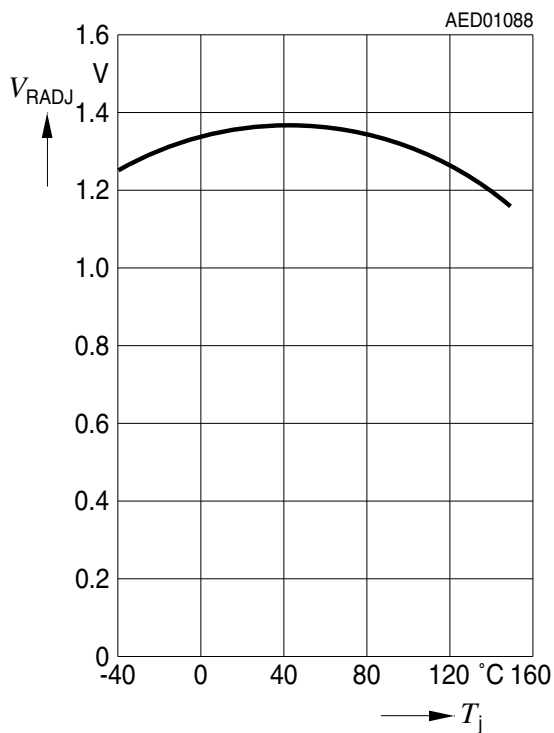

Current Consumption of Inhibit versus Temperature

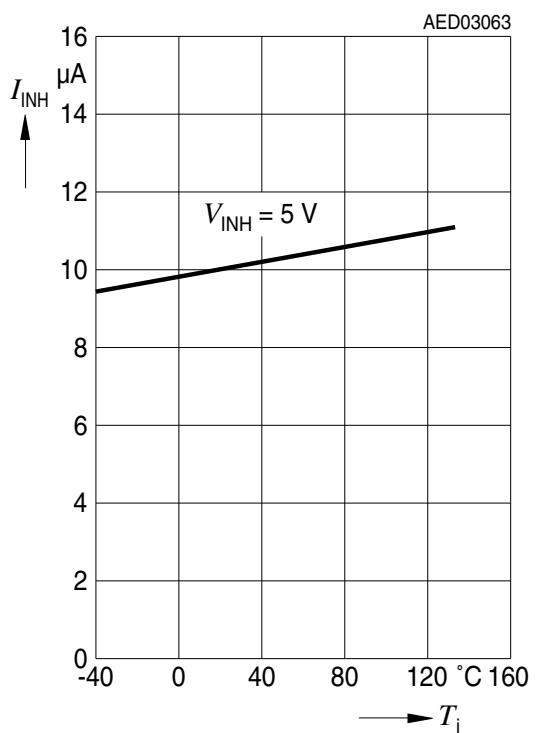

Drop Voltage versus Output Current

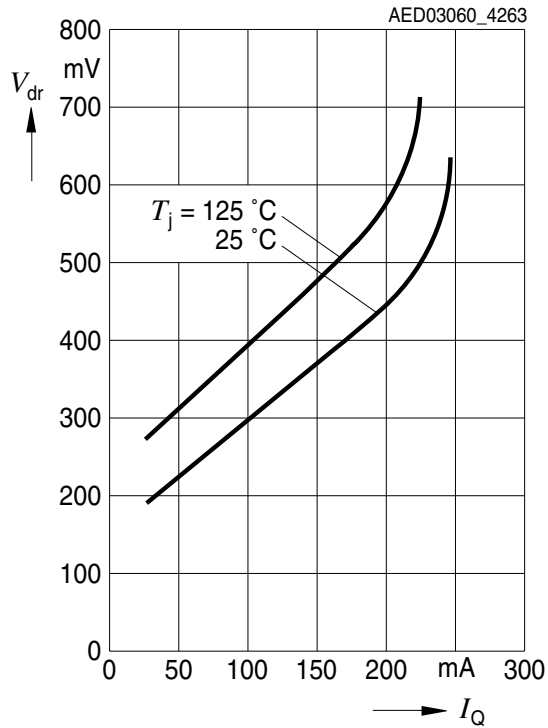

Current Consumption versus Output Current

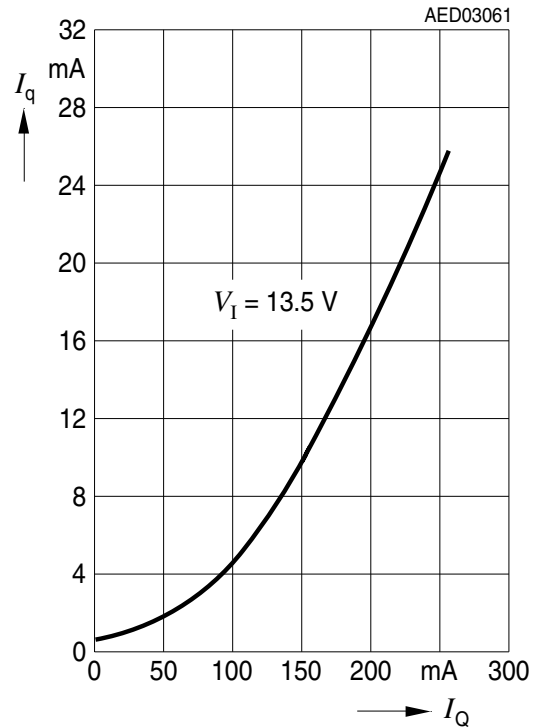

Current Consumption versus Input Voltage

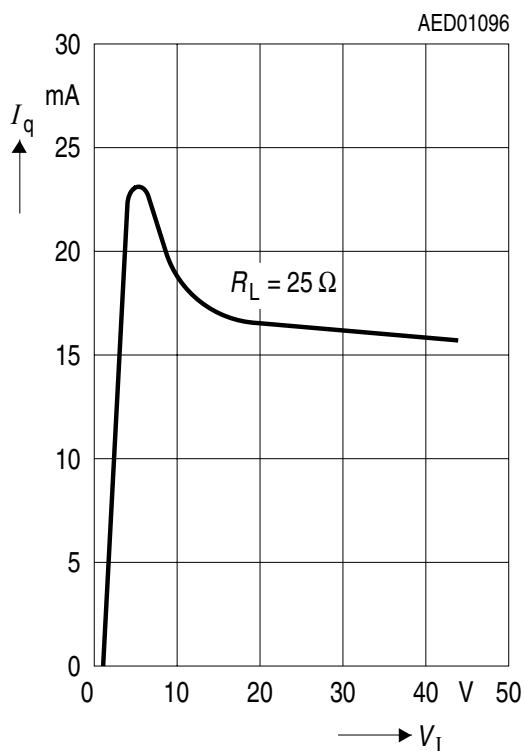

Output Voltage versus Input Voltage

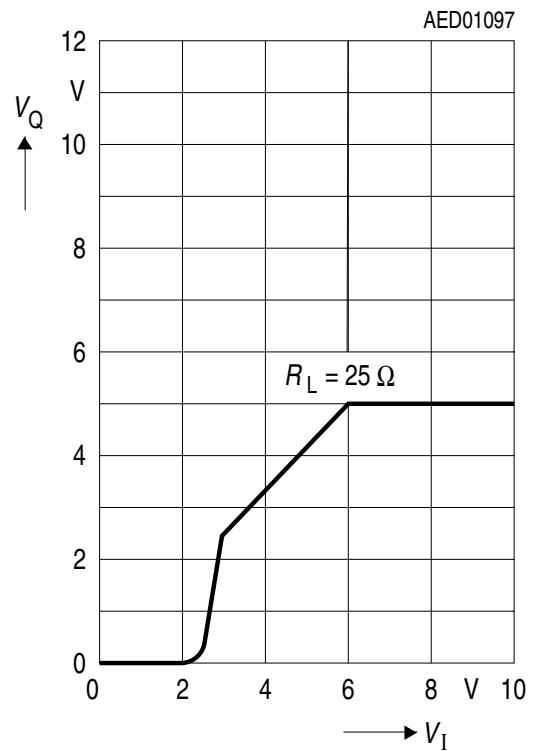

Charge Current and Discharge Current versus Temperature

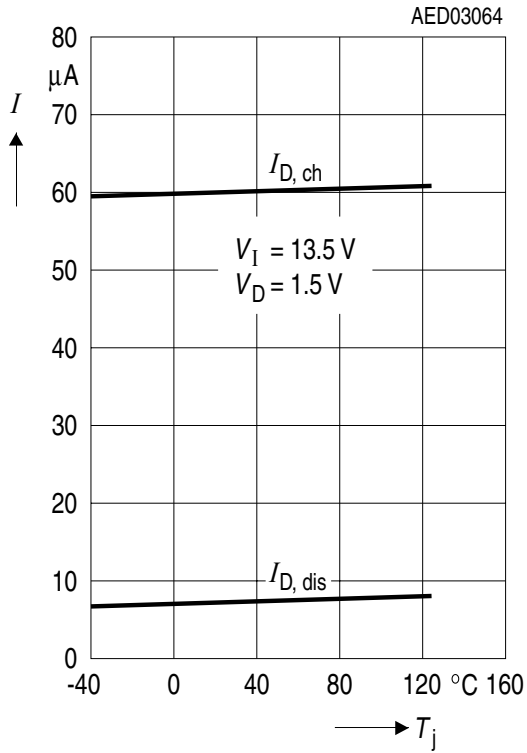

Output Voltage versus Temperature

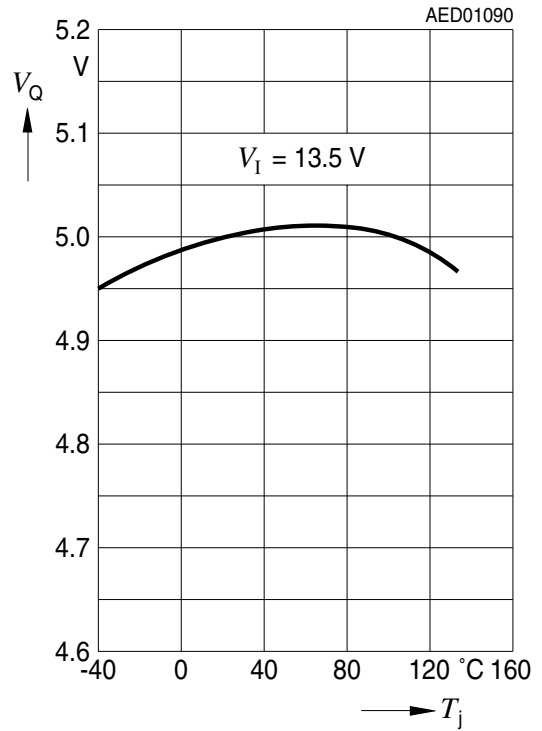

Pulse Time versus Temperature

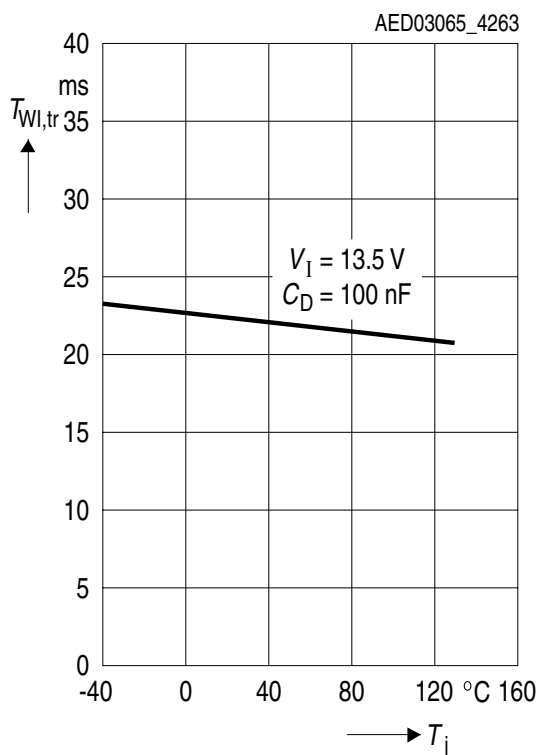

Output Current versus Input Voltage

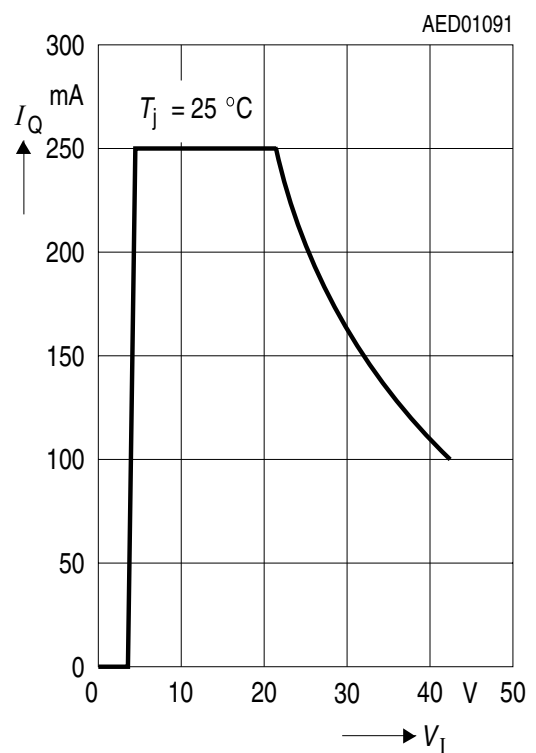

Package Outlines

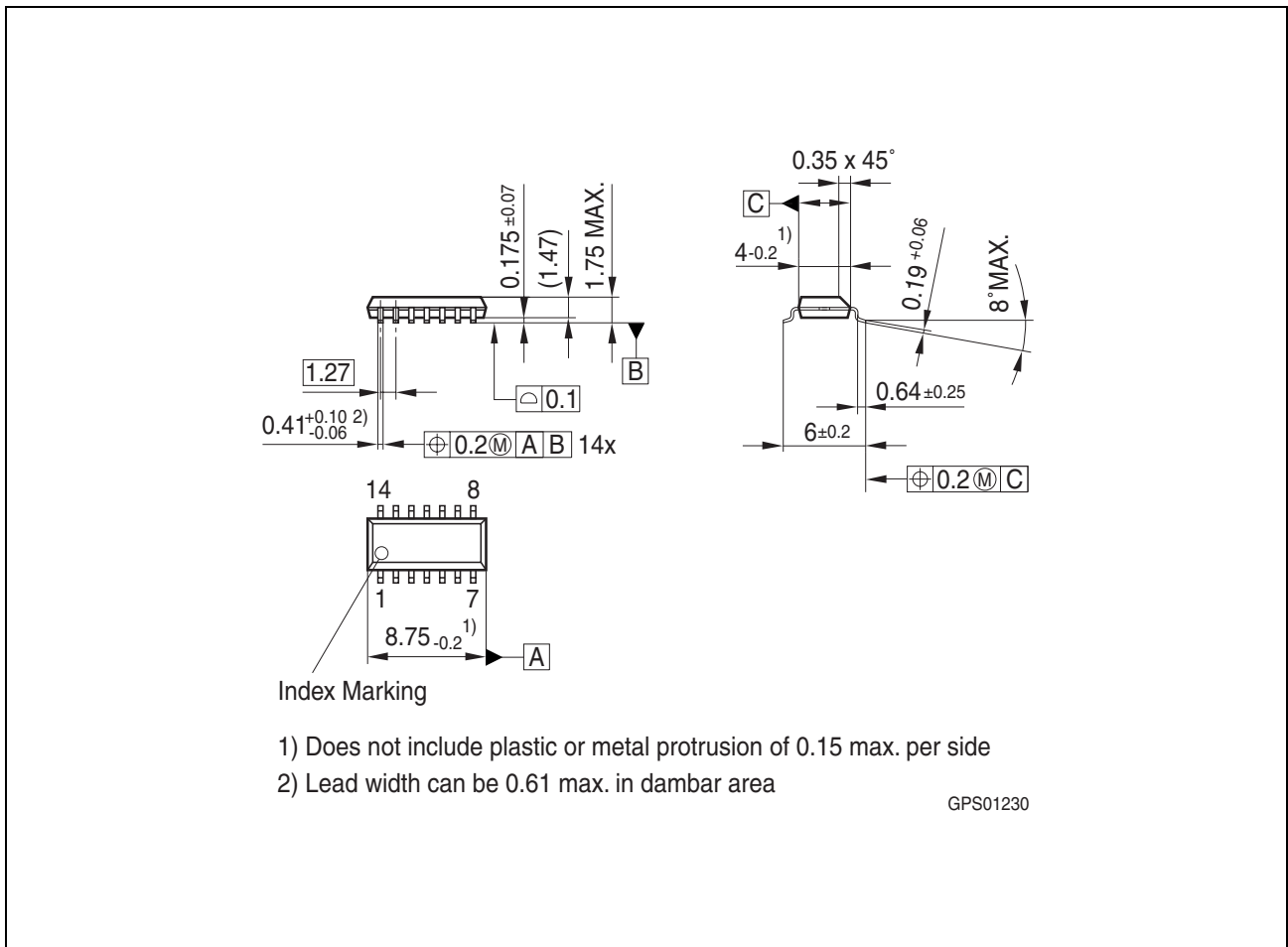

Figure 7 PG-DSO-14-30 (Plastic Dual Small Outline)

Green Product (RoHS compliant)

To meet the world-wide customer requirements for environmentally friendly products and to be compliant with government regulations the device is available as a green product. Green products are RoHS-Compliant (i.e Pb-free finish on leads and suitable for Pb-free soldering according to IPC/JEDEC J-STD-020).

You can find all of our packages, sorts of packing and others in our Infineon Internet Page "Products": <http://www.infineon.com/products>.

SMD = Surface Mounted Device

Dimensions in mm

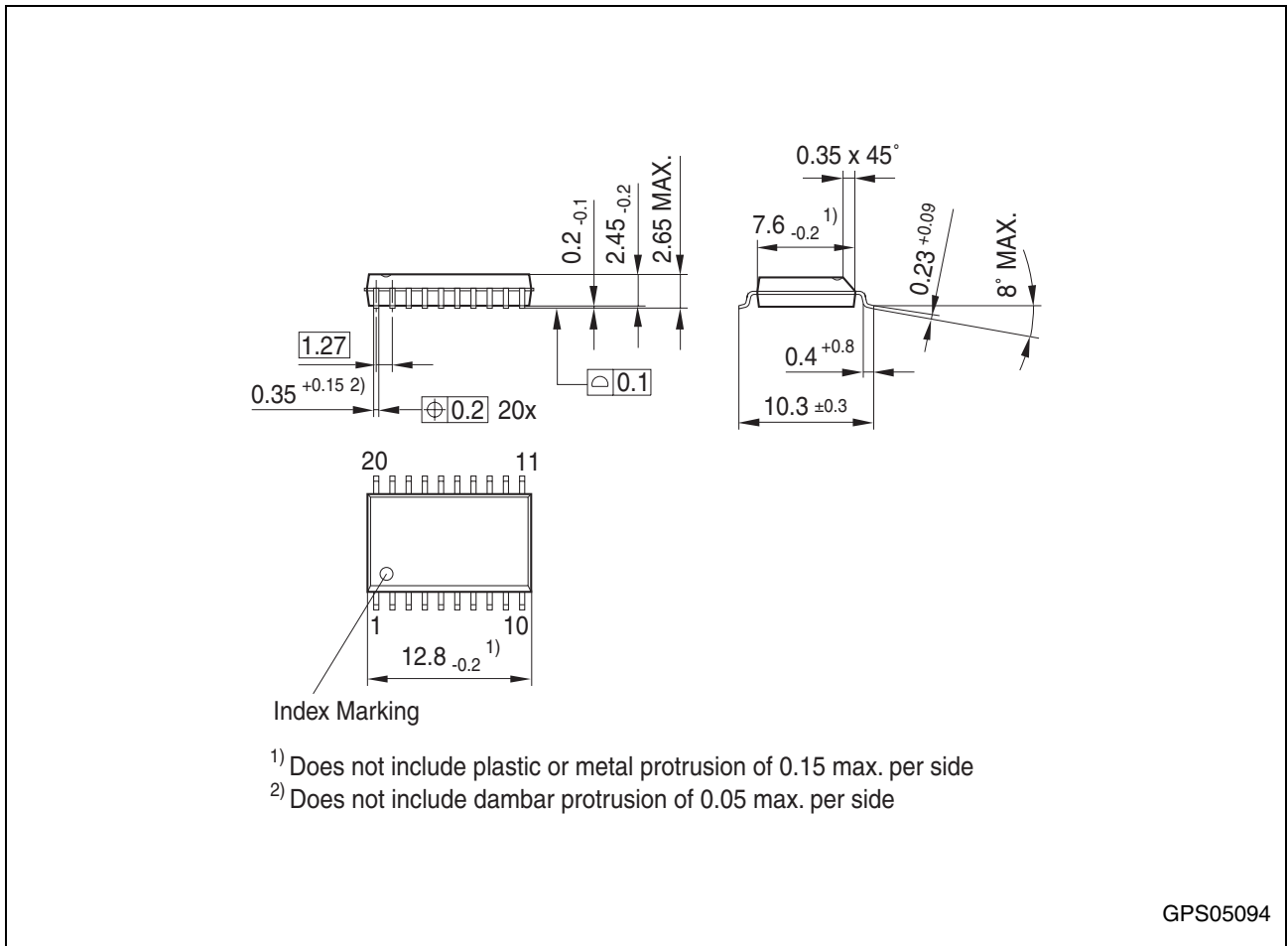

Figure 8 PG-DSO-20-35 (Plastic Dual Small Outline)

Green Product (RoHS compliant)

To meet the world-wide customer requirements for environmentally friendly products and to be compliant with government regulations the device is available as a green product. Green products are RoHS-Compliant (i.e Pb-free finish on leads and suitable for Pb-free soldering according to IPC/JEDEC J-STD-020).

You can find all of our packages, sorts of packing and others in our Infineon Internet Page “Products”: <http://www.infineon.com/products>.

SMD = Surface Mounted Device

Dimensions in mm

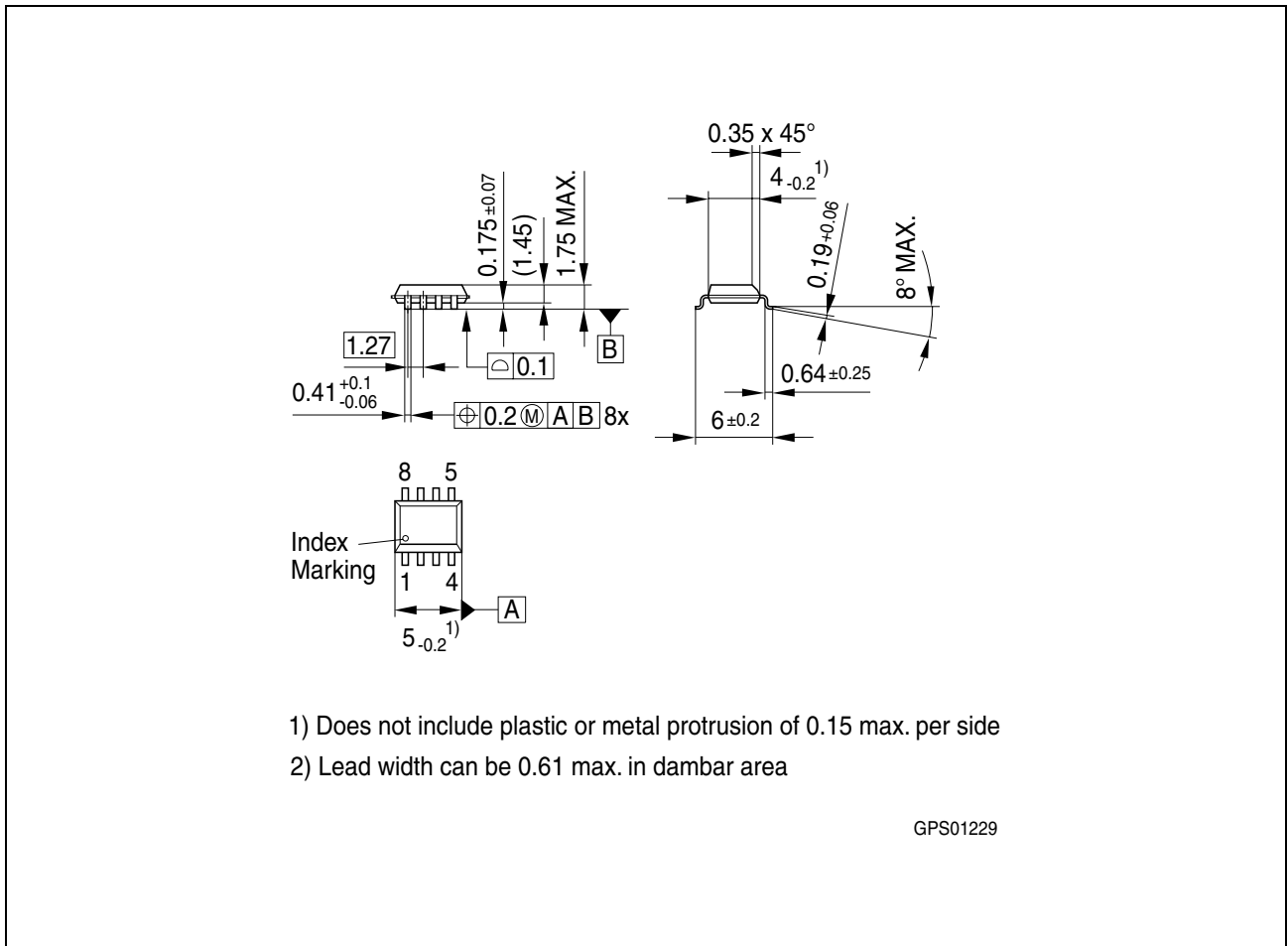

Figure 9 PG-DSO-8-16 (Plastic Dual Small Outline)

Green Product (RoHS compliant)

To meet the world-wide customer requirements for environmentally friendly products and to be compliant with government regulations the device is available as a green product. Green products are RoHS-Compliant (i.e Pb-free finish on leads and suitable for Pb-free soldering according to IPC/JEDEC J-STD-020).

You can find all of our packages, sorts of packing and others in our Infineon Internet Page "Products": <http://www.infineon.com/products>.

SMD = Surface Mounted Device

Dimensions in mm

Revision History

Version	Date	Changes
Rev. 2.8	2007-03-20	Initial version of RoHS-compliant derivate of TLE 4263 Page 1 : AEC certified statement added Page 1 and Page 15 ff:RoHS compliance statement and Green product feature added Page 1 and Page 15 ff: Package changed to RoHS compliant version Legal Disclaimer updated

Edition 2007-03-20

**Published by
Infineon Technologies AG
81726 Munich, Germany**

**© 2007 Infineon Technologies AG
All Rights Reserved.**

Legal Disclaimer

The information given in this document shall in no event be regarded as a guarantee of conditions or characteristics. With respect to any examples or hints given herein, any typical values stated herein and/or any information regarding the application of the device, Infineon Technologies hereby disclaims any and all warranties and liabilities of any kind, including without limitation, warranties of non-infringement of intellectual property rights of any third party.

Information

For further information on technology, delivery terms and conditions and prices, please contact the nearest Infineon Technologies Office (www.infineon.com).

Warnings

Due to technical requirements, components may contain dangerous substances. For information on the types in question, please contact the nearest Infineon Technologies Office.

Infineon Technologies components may be used in life-support devices or systems only with the express written approval of Infineon Technologies, if a failure of such components can reasonably be expected to cause the failure of that life-support device or system or to affect the safety or effectiveness of that device or system. Life support devices or systems are intended to be implanted in the human body or to support and/or maintain and sustain and/or protect human life. If they fail, it is reasonable to assume that the health of the user or other persons may be endangered.